

Capture 100% of Your Rain Water

RAIN-RETURN[®] PACKAGED RAIN HARVESTING SYSTEM



With less rain fall predicted now at last

you can capture all the water from the roof.

Now with Rain-Return you can turn a typical rain water tank system into a complete rainwater harvesting system.

Rain-Return is a cost effective pre-packaged system ready to be installed. Typical domestic rain water systems collect less than 10% of the roof area while 90% of the rain water disappears down the drain.

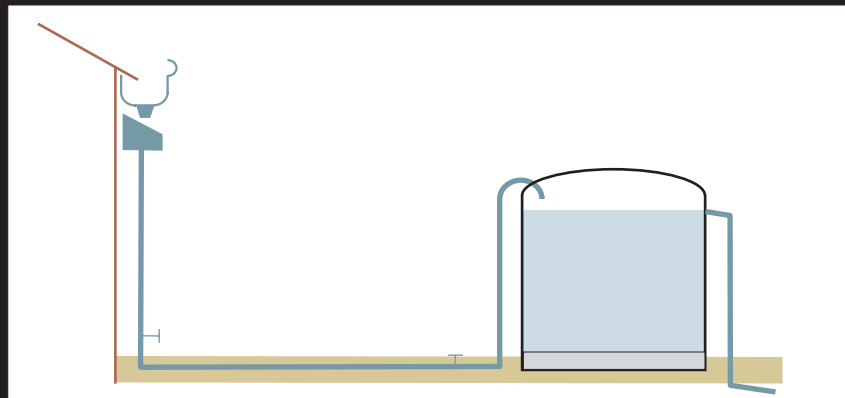

Eliminates unhealthy, expensive Charged Down Pipe Systems

3 Easy to install Components (Pre-packaged ready for installation)

1. Rain-Return Tank Level Switch

The Patented System includes a level switch which stops the pump filling the storage tank

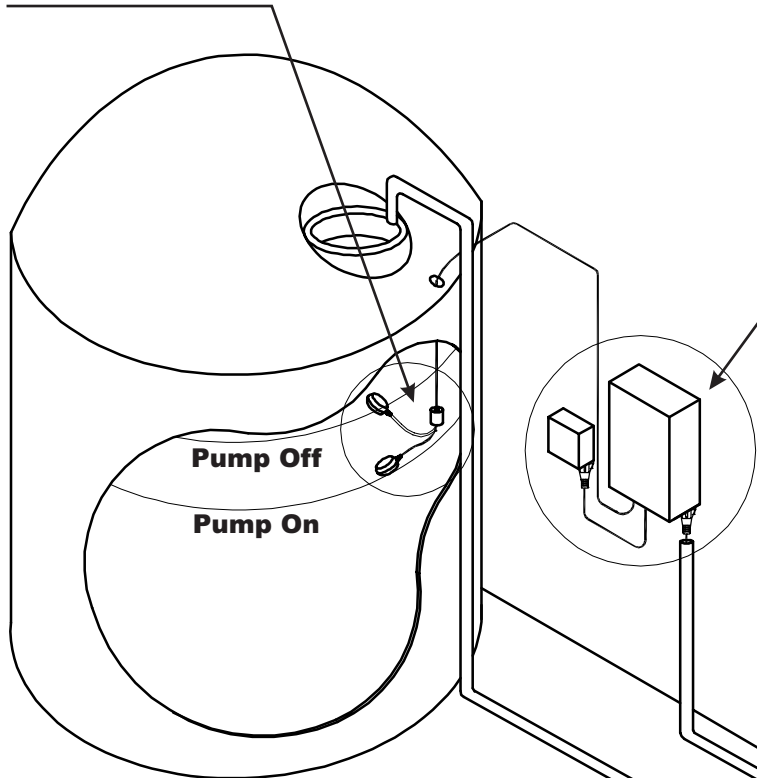

2. Rain-Return Pump Controller

Pump & Level Switch DIY plugs into the main controller

Rain Water Storage Tank (Not Supplied)

3. Rain-Return Pre Packaged Pump Pit

- Automatic by-pass if power fails
- Stainless Steel pumps
- Pre-plumbed ready for installation
- Packages available up to 2000m² catchment

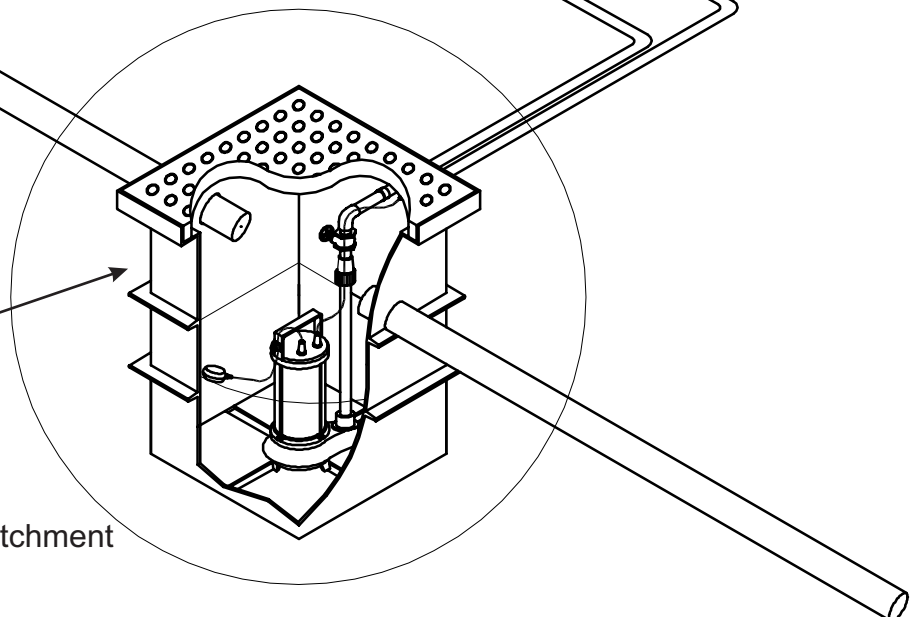

DTB International Pumping 122 - 124 St Kilda Rd St Kilda Victoria 3182

PHONE: 03 9525 3844 FAX: 03 9525 3640 EMAIL: sales@dtbpumps.com

www.dtbpumps.com